

DALMAN Co. (PVT) Ltd.

33KV PFC-33 Silicone rubber Fuse Cutout



Technical Specifications:

| Rated Voltage (KV) | Rated Current (A) | Interrupting current (KA) | Power Frequency withstand voltage (KV) | Impulse withstand Voltage (KV) | Creepage distance to ground (mm) |
|--------------------|-------------------|---------------------------|--|--------------------------------|----------------------------------|
| 36 | 100 | 8 (sym.) | 70 | 190 | 1130 |



Manufacturer of M.V. Drop-out Open Fuse Cutouts and Fuselinks

DALMAN CO. (PVT) Ltd.
Razi Bldg. Fakhre- Razi St.
Enghelab Ave.
TEHRAN 1314753933 - IRAN
P.O.Box 13145 - 1858

Tel. 66469022, 66409993
Fax. +98 21 66410040
E-mail:
Info@dalman-co.com
www.dalman-co.com

Factory: Km 5, Qazvin Road
P.O.Box 34815 – 389
TAKESTAN – IRAN
Tel. 3522 5131,2
Fax. +98 28 3522 1548

Banker:
Bank Melli Iran
Daneshgah Branch
Acct.: 87/700385

DALMAN COMPANY

APPLICATION

DALMAN Type FC Cutouts provide complete over current protection to overhead distribution system rated 15 KV though 38 KV, whether applied to overhead transformers, capacitors, cables, or lines. These cutouts accommodate universal button head fuse links through 200A. Fuseholders with / or without arc shortening rod for heavy –duty, extra heavy- duty, or ultra heavy –duty interrupting ratings and 300A disconnecting switchblade interchangeable with fuse holder, equip FC Cutouts for a wide range of application.

SPECIFICATION

| Voltage Rating (KV) | | B.I.L (KV) | Current Rating | | Creepage Distance to Ground | Catalog Number 51- - |
|---------------------|-------------|---------------|----------------|---------------------------|-----------------------------------|----------------------------|
| Nominal | Max. Design | | Cont.(A) | Interrupting Asym.(KA) | | |
| 25 | 27 | 125 | 100 | 8 | 24" (600mm) | 511-11-241-P |
| | | | | 12, 16 | 24" (600mm) | 511-21-241-P* |
| 25 | 27 | 185 | 100 | 8 | 34" (860mm) | 511-11-341-P |
| | | | | 12, 16 | 34" (860mm) | 511-21-341-P* |
| 34.5 | 38 | 170 | 100 | 8 | 44" (1130mm) | 511-11-441-P |
| | | | | 12, 16 | 44" (1130mm) | 511-21-441-P* |
| 34.5 | 38 | 170 | 100 | 8 | 48" (1212mm) | 511-11-481-P |
| | | | | 12, 16 | 48" (1212mm) | 511-21-481-P* |

* Equipped with arc shortening rod, required removable button head fuse link.
One shot rating based on replacement of cut out tube only.
With polymer insulator.

All ferrous parts are hot dip galvanized per ASTM A- 153

Fuse Cutouts with higher Creepage distances, and interrupting currents upon request.

STANDARD: ANSI C37.42 , IEC 60282-2

ISO 9001:2000 CERTIFIED COMPANY

<http://www.dalman-co.com> Email : info@dalman-co.com

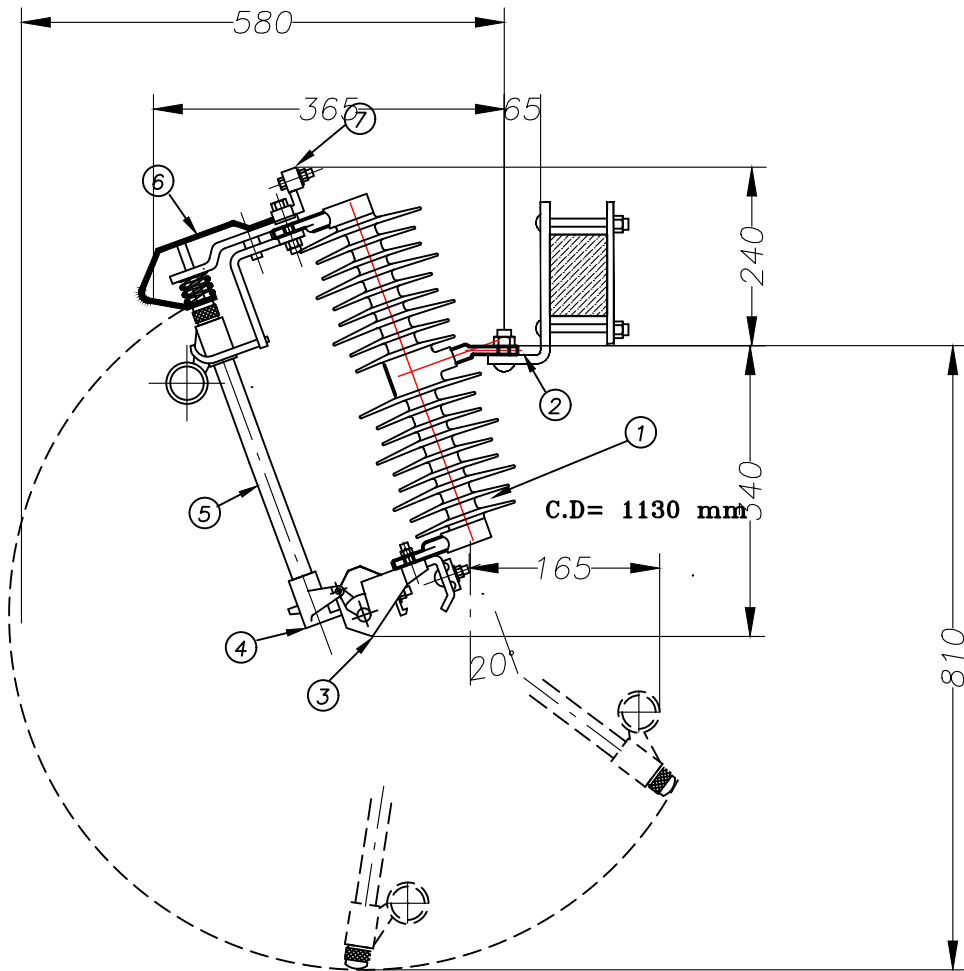

Drop-Out Fuse Cutout

| | | |
|-----------------------------------|---------|------|
| a) Creepage Distance | mm | 1130 |
| b) Nominal Voltage | KV | 34.5 |
| c) Max. Design Voltage | KV | 38 |
| d) Continuous Current | A | 100 |
| e) Interr. Current (Asym.) | KA | 12 |
| f) Min. Power Frequency Withstand | KV(Dry) | 85 |
| g) Min. Impulse Withstand | KV | 185 |

| Item | Description | Qty |
|------|--|-----|
| 7 | DIECAST BRASS | 1 |
| 6 | Electric Copper | 1 |
| 5 | Vulcanized Tube Reinforced with Fiber Glass | 1 |
| 4 | DIECAST BRASS | 1 |
| 3 | DIECAST BRASS | 1 |
| 2 | NEMA Mounting Bracket | 1 |
| 1 | Silicone Rubber Insulator | 1 |

| توضیحات | | انطباقات عمومی FREE TOLERANCES ISO 286-2 | | DALMAN | | DALMAN CO.(PVT) LTD, TEHRAN | |
|------------------------|---------|--|-------|--------|---------|--|------------|
| کلیه ابعاد به میلی متر | | | | | | کارفرما: | |
| تاریخ | تغییرات | نام | شماره | تاریخ | نام | Orderd by: | |
| | | | ۱ | | طرا b | Dwg.Title: | جنس |
| | | | ۲ | | رسم | Drop out Fuse Cutout Type PFC 34.5 KV, 100 A, Silicone Rubber | وزن |
| | | | ۳ | | کنترل | | مقیاس |
| | | | ۴ | | تصویب ۱ | Ref. Code | تعداد |
| | | | ۵ | | تصویب ۲ | DWG.NO: 3116-P33 | برگ |
| | | | | | | عنوان نقشه: | شماره مرجع |
| | | | | | | شماره نقشه | |